

# DESIGN NOTES

## Single Inductor, Tiny Buck-Boost Converter Provides 95% Efficiency in Lithium-Ion to 3.3V Applications – Design Note 275

Mark Jordan

### Introduction

In portable applications powered by a single lithium-ion cell, the input voltage can typically change from 4.2V initially, down to 2.5V at end of life. It is a challenging task to provide a regulated voltage within the range of the battery. Until now, the most popular solution has been the SEPIC converter, but its mediocre efficiency and requirement of both a coupled inductor and a high current flyback capacitor make it a less than optimal solution. Another option is to cascade a Boost converter with either an LDO or a Buck converter, but the additional area and cost of the extra components, as well as low efficiency, are major drawbacks. Linear Technology's new LTC<sup>®</sup>3440 Buck-Boost converter provides the most compact solution with the highest efficiency, thereby reducing cost, increasing battery life and saving precious real estate.

The LTC3440 incorporates a patent-pending control technique to efficiently regulate an output voltage above, below or equal to the input source voltage with a single inductor by properly phasing the four internal switches. Efficiencies well over 90% are achieved for the entire battery range without the use of Schottky rectifier diodes. The low  $R_{DS(ON)}$  (0.19 $\Omega$  NMOS, 0.22 $\Omega$  PMOS), low gate charge synchronous switches, along with minimal break-before-make times, provide high frequency, low noise operation with high efficiency. For light loads, the part

offers user controlled Burst Mode<sup>®</sup> operation to maximize battery life, drawing only 25 $\mu$ A of quiescent current. The operating frequency can be programmed from 300KHz to 2MHz by changing the value of the timing resistor on the  $R_T$  pin. Users can synchronize the operating frequency by connecting an external clock to the MODE/SYNC pin. The part can also be commanded to shut down by pulling the SHDN/SS pin low. In shutdown, the part draws less than 1 $\mu$ A of quiescent current and disconnects the output from the input supply. During start-up, the ramp rate of the output voltage is controlled by the external soft-start components. This controlled ramp rate provides for inrush current limiting. Housed in a thermally enhanced 10-lead MSOP package, the LTC3440 is ideal for portable power applications requiring less than 2W of output power.

### All Ceramic Capacitor, Single Inductor, 2W Li-Ion to 3.3V Converter

An all-ceramic capacitor, lithium-ion to 3.3V application at 600mA is shown in Figure 1. The operating frequency is programmed to 1MHz and soft-start is incorporated with R4 and C3. The efficiency curves versus load current for the Li-Ion battery range are shown in Figure 2. With Burst Mode operation enabled at light loads, efficiencies

**LT**, LTC and LT are registered trademarks of Linear Technology Corporation. Burst Mode is a registered trademark of Linear Technology Corporation.

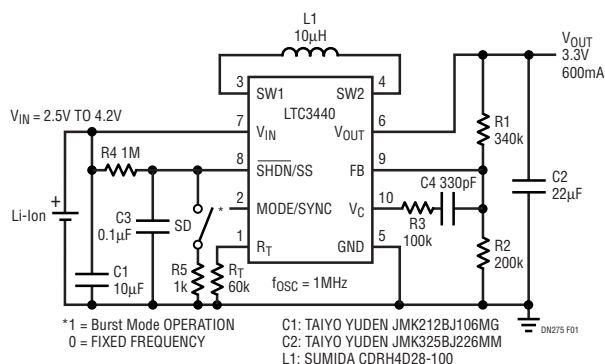

Figure 1. Simple Lithium-Ion to 3.3V Converter at 600mA

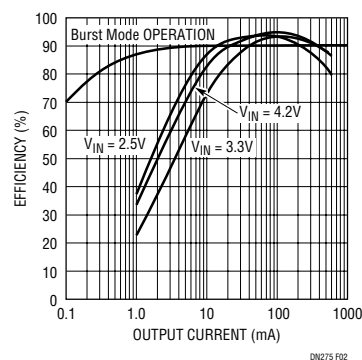

Figure 2. Li-Ion to 3.3V Efficiency

of over 85% are achieved for more than three decades of load current. At 200 $\mu$ A, the efficiency remains above 70%, primarily due to the low 25 $\mu$ A quiescent current in Burst Mode operation. In many applications the decreased load demand on the converter is known by the application and the converter can be commanded to enter power saving Burst Mode operation by driving the MODE/SYNC pin high.

### WCDMA Dynamically Controlled Power Amp Power Supply

For the new 3rd generation (3G) cellular phones, the high speed data transmission imposes a stringent power demand on the battery. Maximum overall efficiency and operation over the entire battery voltage range are required to maximize run time. A 2W, dynamically controlled power supply for a WCDMA cell phone power amplifier (PA) is shown in Figure 3. By adjusting the voltage across the PA, the overall efficiency to the antenna is improved, and a linear PA can be utilized. At peak power, the PA requires the highest programmed voltage, typically 3.4V to 4V depending on the PA. At the lowest power level, when only voice is transmitted and the user is close to the basestation, the PA draws less than 100mA and requires a lower voltage, typically between 0.4V to 2V. Since the LTC3440 can regulate an output voltage above, below or equal to the battery voltage, the maximum transmit power can be maintained over the entire voltage range. For applications requiring a program voltage below 2V, a Schottky diode is required from the SW2 to V<sub>OUT</sub> pins to provide a low impedance power path since the internal synchronous switch loses gate drive at low output

voltage. Figure 4 demonstrates the efficiency of the converter versus input voltage at various load currents. The transient response of the power converter for a 1.5V output voltage change, commanded by the DAC, is shown in Figure 5.

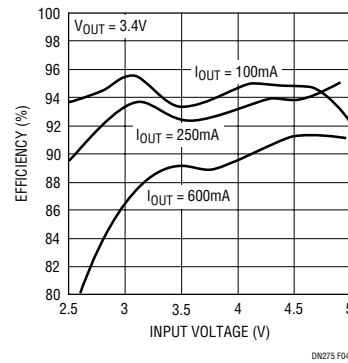

Figure 4. Efficiency of the WCDMA Power Amp Power Supply

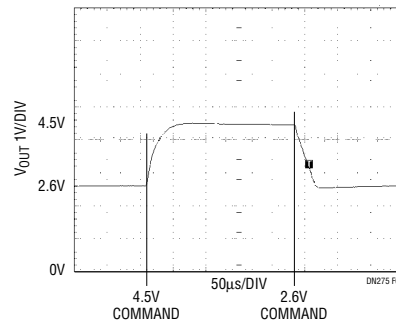

Figure 5. Output Voltage Transient Response of the WCDMA Power Supply

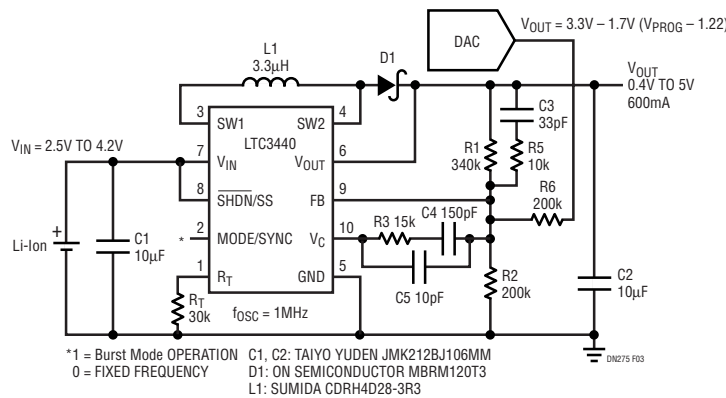

Figure 3. WCDMA Power Amp Power Supply with Dynamic Voltage Control

#### Data Sheet Download

<http://www.linear.com/go/dnLTC3440>

For literature on our Buck-Boost Converters, call 1-800-4-LINEAR. For applications help, call (408) 432-1900, Ext. 2759